

SOLUTIONS & ANSWERS FOR JEE MAINS-2021
18th March Shift 1

[PHYSICS, CHEMISTRY & MATHEMATICS]

PART – A – PHYSICS

SECTION A

Q.1 A thin circular ring of mass M and radius r is rotating about its axis with an angular speed ω . Two particles having mass m each are now attached at diametrically opposite points. The angular speed of the ring will become :

Options

1. $\omega \frac{M - 2m}{M + 2m}$

2. $\omega \frac{M + 2m}{M}$

3. $\omega \frac{M}{M + 2m}$

4. $\omega \frac{M}{M + m}$

Ans: 3

Sol: Using conservation of angular momentum

$$(Mr^2)\omega = (Mr^2 + 2mr^2)\omega'$$

$$\omega' = \frac{M\omega}{M + 2m}$$

Q.2 In the experiment of Ohm's law, a potential difference of 5.0 V is applied across the end of a conductor of length 10.0 cm and diameter of 5.00 mm. The measured current in the conductor is 2.00 A. The maximum permissible percentage error in the resistivity of the conductor is :

Options

1. 8.4

2. 3.0

3. 7.5

4. 3.9

Ans: 4

Sol: Resistance $R = \frac{\rho \ell}{A} = \frac{V}{I}$

$$\rho = \frac{AV}{I\ell} = \frac{\pi d^2 V}{4I\ell} \left(\text{Area } A = \frac{\pi d^2}{4} \right)$$

$$\begin{aligned} \therefore \frac{\Delta\rho}{\rho} &= \frac{2\Delta d}{d} + \frac{\Delta V}{V} + \frac{\Delta I}{I} + \frac{\Delta\ell}{\ell} \\ &= 2\left(\frac{0.01}{5.00}\right) + \frac{0.1}{5.0} + \frac{0.01}{2.00} + \frac{0.1}{10.0} \end{aligned}$$

$$\frac{\Delta\rho}{\rho} = 0.004 + 0.02 + 0.005 + 0.01$$

$$\% \text{ error} = \frac{\Delta\rho}{\rho} \times 100 = 0.039 \times 100 = 3.90\%$$

Q.3 In a series LCR resonance circuit, if we change the resistance only, from a lower to higher value :

Options 1.

1. The quality factor and the resonance frequency will remain constant
2. The bandwidth of resonance circuit will increase
3. The quality factor will increase
4. The resonance frequency will increase

Ans: 2

Sol: Band width = $\frac{R}{L}$
 Band width $\propto R$
 So band width will increase

Q.4 A loop of flexible wire of irregular shape carrying current is placed in an external magnetic field. Identify the effect of the field on the wire.

Options 1. shape of the loop remains unchanged

2. loop assumes circular shape with its plane normal to the field
3. loop assumes circular shape with its plane parallel to the field
4. wire gets stretched to become straight

Ans: 2

Sol: Every part (dl) of the wire is pulled by force $i(dl) B$ acting perpendicular to current and magnetic field giving it a shape of circle

Q.5 A constant power delivering machine has towed a box, which was initially at rest, along a horizontal straight line. The distance moved by the box in time 't' is proportional to :

Options 1. $t^{2/3}$

2. t

3. $t^{1/2}$

4. $t^{3/2}$

Ans: 4

Sol: $P = \text{constant}$
 $FV = \text{constant}$

$$M \left(\frac{dV}{dt} \right) V = \text{constant} \quad \frac{dV}{dt} = \text{acceleration} = a$$

$$Ma = F$$

$$M V dV = \text{constant} dt$$

On integrating

$$\frac{V^2}{2} \propto t$$

$$V \propto t^{1/2}$$

$$\frac{dx}{dt} \propto t^{1/2} \Rightarrow dx \propto t^{1/2} dt$$

$$\text{On integrating, } x \propto t^{3/2}$$

Q.6 Match List - I with List - II.

List - I

- (a) 10 km height over earth's surface
- (b) 70 km height over earth's surface
- (c) 180 km height over earth's surface
- (d) 270 km height over earth's surface

List - II

- (i) Thermosphere
- (ii) Mesosphere
- (iii) Stratosphere
- (iv) Troposphere

Options 1. (a)-(i), (b)-(iv), (c)-(iii), (d)-(ii)

2. (a)-(iv), (b)-(iii), (c)-(ii), (d)-(i)

3. (a)-(iii), (b)-(ii), (c)-(i), (d)-(iv)

4. (a)-(ii), (b)-(i), (c)-(iv), (d)-(iii)

Ans: 2

Sol: Layers of atmosphere are

- | | |
|--------------|-----------|
| Troposphere | a → (iv) |
| Stratosphere | b → (iii) |
| Mesosphere | c → (ii) |
| Thermosphere | d → (i) |

Q.7 An AC source rated 220 V, 50 Hz is connected to a resistor. The time taken by the current to change from its maximum to the rms value is :

- Options**
1. 0.25 ms
 2. 25 ms
 3. 2.5 ms
 4. 2.5 s

Ans: 3

Sol: $i = i_0 \cos(\omega t)$

$$i = i_0 \text{ at } t = 0$$

$$i = \frac{i_0}{\sqrt{2}} \text{ at } \omega t = \frac{\pi}{4}$$

$$t = \frac{\pi}{4\omega} = \frac{\pi}{4(2\pi f)} = \frac{1}{8f}$$

$$t = \frac{1}{400} = 2.5 \text{ ms}$$

Q.8 The time period of a simple pendulum is given by $T = 2\pi\sqrt{\frac{l}{g}}$. The measured value of the length of pendulum is 10 cm known to a 1 mm accuracy. The time for 200 oscillations of the pendulum is found to be 100 second using a clock of 1 s resolution. The percentage accuracy in the determination of 'g' using this pendulum is 'x'. The value of 'x' to the nearest integer is,

- Options**
1. 4 %
 2. 2 %
 3. 5 %
 4. 3 %

Ans: 4

Sol: $g = \frac{4\pi^2 l}{T^2} \left[\because T = 2\pi\sqrt{\frac{l}{g}} \right]$

$$\frac{\Delta g}{g} = \frac{\Delta l}{l} + 2 \frac{\Delta T}{T}$$

$$= \frac{0.1}{10} + 2 \left(\frac{1}{0.5} \right)$$

$$\frac{\Delta g}{g} = \frac{1}{100} + \frac{1}{50} = \frac{1+2}{100} = \frac{3}{100}$$

$$\frac{\Delta g}{g} \times 100 = \frac{3}{100} \times 100 = 3\%$$

- Q.9** Four identical long solenoids A, B, C and D are connected to each other as shown in the figure. If the magnetic field at the center of A is 3 T, the field at the center of C would be : (Assume that the magnetic field is confined within the volume of respective solenoid).

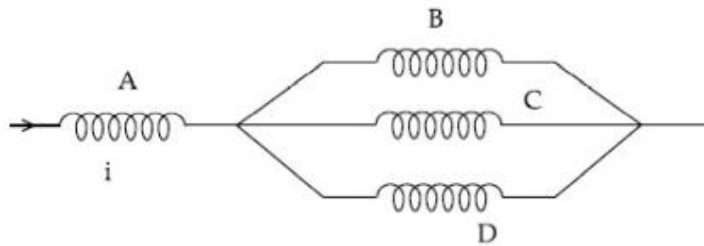

- Options**
1. 6 T
 2. 12 T
 3. 9 T
 4. 1 T

Ans: 4

Sol: $\phi \propto i$
 $\Rightarrow B \propto i$

So field at centre of C = $\frac{3}{3} = 1\text{T}$

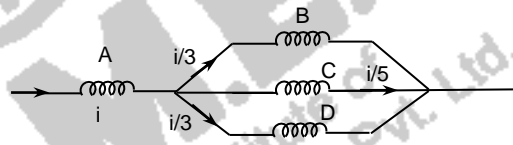

- Q.10** A radioactive sample disintegrates via two independent decay processes having half lives $T_{1/2}^{(1)}$ and $T_{1/2}^{(2)}$ respectively. The effective half-life, $T_{1/2}$ of the nuclei is :

Options 1. None of the above

2. $T_{1/2} = T_{1/2}^{(1)} + T_{1/2}^{(2)}$

3. $T_{1/2} = \frac{T_{1/2}^{(1)} + T_{1/2}^{(2)}}{T_{1/2}^{(1)} - T_{1/2}^{(2)}}$

4. $T_{1/2} = \frac{T_{1/2}^{(1)} T_{1/2}^{(2)}}{T_{1/2}^{(1)} + T_{1/2}^{(2)}}$

Ans: 4

Sol: $\lambda_{eq} = \lambda_1 + \lambda_2$

$$\frac{1}{T_{\frac{1}{2}}} = \frac{1}{T_{\frac{1}{2}}^{(1)}} + \frac{1}{T_{\frac{1}{2}}^{(2)}}$$

$$T_{\frac{1}{2}} = \frac{T_{\frac{1}{2}}^{(1)} \times T_{\frac{1}{2}}^{(2)}}{T_{\frac{1}{2}}^{(1)} + T_{\frac{1}{2}}^{(2)}}$$

Q.11 In Young's double slit arrangement, slits are separated by a gap of 0.5 mm, and the screen is placed at a distance of 0.5 m from them. The distance between the first and the third bright fringe formed when the slits are illuminated by a monochromatic light of 5890 Å is :

- Options**
1. 1178×10^{-12} m
 2. 1178×10^{-9} m
 3. 1178×10^{-6} m
 4. 5890×10^{-7} m

Ans: 3

Sol: $\beta = \frac{\lambda D}{d}$

$$= \frac{5890 \times 10^{-10} \times 0.5}{0.5 \times 10^{-3}} = 589 \times 10^{-6} \text{ m}$$

Distance between first and third bright fringe is
 $2\beta = 2 \times 589 \times 10^{-6} \text{ m} = 1178 \times 10^{-6} \text{ m}$

Q.12 The P-V diagram of a diatomic ideal gas system going under cyclic process as shown in figure. The work done during an adiabatic process CD is (use $\gamma = 1.4$) :

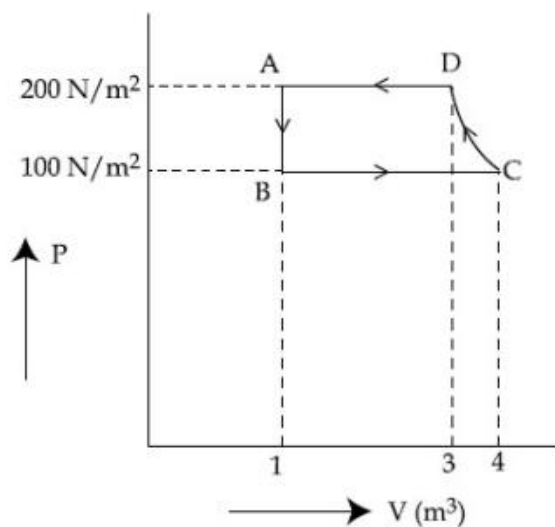

- Options
1. 200 J
 2. -400 J
 3. -500 J
 4. 400 J

Ans: 3

Sol: Adiabatic process is from C to D

$$\begin{aligned} \text{Work done} &= \frac{P_2V_2 - P_1V_1}{1-\gamma} = \frac{P_DV_D - P_CV_C}{1-\gamma} \\ &= \frac{200(3) - 100(4)}{1-1.4} = -500 \text{ J} \end{aligned}$$

Q.13 What will be the average value of energy along one degree of freedom for an ideal gas in thermal equilibrium at a temperature T ? (k_B is Boltzmann constant)

- Options
1. $k_B T$
 2. $\frac{3}{2} k_B T$
 3. $\frac{2}{3} k_B T$
 4. $\frac{1}{2} k_B T$

Ans: 4

Sol: Energy associated with each degree of freedom per molecule = $\frac{1}{2} k_B T$

Q.14 The position, velocity and acceleration of a particle moving with a constant acceleration can be represented by :

Options 1.

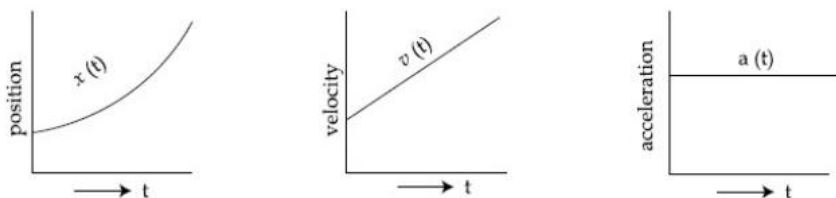

2.

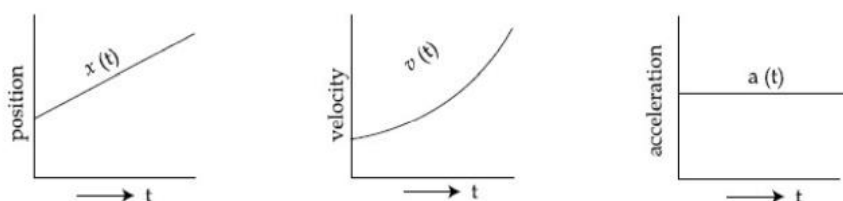

3.

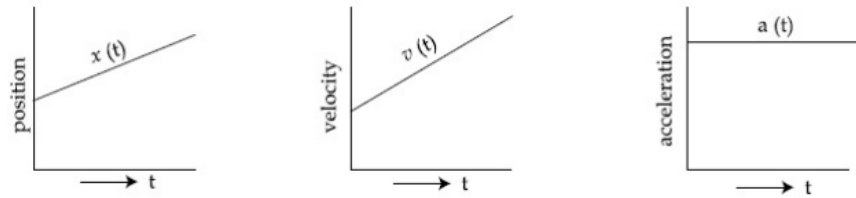

4.

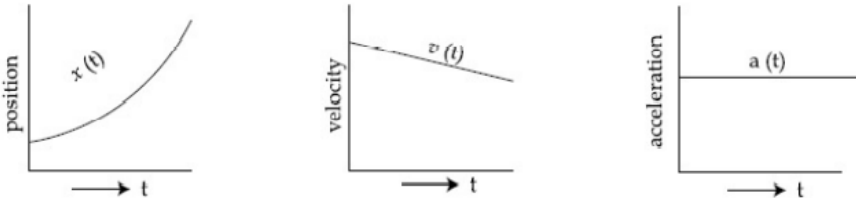

Ans: 1

Sol: Option (1) represent correct graph for particle moving with constant acceleration, as for constant acceleration velocity time graph is a straight line with positive slope and $x - t$ graph should be an opening upward parabola

Q.15 Imagine that the electron in a hydrogen atom is replaced by a muon (μ). The mass of muon particle is 207 times that of an electron and charge is equal to the charge of an electron. The ionization potential of this hydrogen atom will be :

- Options
1. 331.2 eV
 2. 2815.2 eV
 3. 13.6 eV
 4. 27.2 eV

Ans: 2

Sol: $E \propto \frac{1}{r}$
 $E \propto \frac{1}{m}$
 $E \propto m$

$$\begin{aligned} \text{Ionization potential} &= 13.6 \times \frac{(\text{Mass}_\mu) \text{eV}}{(\text{mass}_e)} \\ &= 13.6 \times 207 \text{ eV} \\ &= 2815.2 \text{ eV} \end{aligned}$$

Q.16 The time period of a satellite in a circular orbit of radius R is T . The period of another satellite in a circular orbit of radius $9R$ is :

- Options**
1. $3 T$
 2. $27 T$
 3. $12 T$
 4. $9 T$

Ans: 2

Sol: $T^2 \propto R^3$

$$\left(\frac{T^1}{T}\right)^2 = \left(\frac{9R}{R}\right)^3$$
$$T^1 = T^2 \times 9^3$$
$$T^1 = T \times 3^3$$
$$T^1 = 27 T$$

Q.17 A particle is travelling 4 times as fast as an electron. Assuming the ratio of de-Broglie wavelength of a particle to that of electron is $2 : 1$, the mass of the particle is :

- Options**
1. 16 times the mass of e^-
 2. $\frac{1}{16}$ times the mass of e^-
 3. $\frac{1}{8}$ times the mass of e^-
 4. 8 times the mass of e^-

Ans: 3

Sol: $\lambda = \frac{h}{p}$

$$\frac{\lambda_p}{\lambda_e} = \frac{p_e}{p_p} = \frac{m_e V_e}{m_p V_p}$$
$$2 = \frac{m_e}{m_p} \left(\frac{V_e}{4V_e} \right)$$
$$\therefore m_p = \frac{m_e}{8}$$

Q.18 Your friend is having eye sight problem. She is not able to see clearly a distant uniform window mesh and it appears to her as non-uniform and distorted. The doctor diagnosed the problem as :

- Options**
1. Presbyopia with Astigmatism
 2. Myopia and hypermetropia
 3. Myopia with Astigmatism
 4. Astigmatism

Ans: 3

Sol: If distant objects are blurry then problem is Myopia.
If objects are distorted then problem is Astigmatism

Q.19 An oil drop of radius 2 mm with a density 3 g cm^{-3} is held stationary under a constant electric field $3.55 \times 10^5 \text{ V m}^{-1}$ in the Millikan's oil drop experiment. What is the number of excess electrons that the oil drop will possess ?

Consider $g = 9.81 \text{ m/s}^2$

- Options**
1. 48.8×10^{11}
 2. 1.73×10^{10}
 3. 1.73×10^{12}
 4. 17.3×10^{10}

Ans: 2

Sol: $qE = mg$

$$neE = \rho \left(\frac{4}{3} \pi r^3 \right) g$$

$$n \times 1.6 \times 10^{-19} \times 3.55 \times 10^5 = 3 \times 10^3 \times \frac{4}{3} \times \pi (2 \times 10^{-3})^3 \times 9.81$$

$$n = 1.73 \times 10^{10}$$

Q.20 A plane electromagnetic wave of frequency 100 MHz is travelling in vacuum along the x-direction. At a particular point in space and time, $\vec{B} = 2.0 \times 10^{-8} \hat{k} \text{ T}$. (where, \hat{k} is unit vector along z-direction) What is \vec{E} at this point ?

(speed of light $c = 3 \times 10^8 \text{ m/s}$)

- Options**
1. $6.0 \hat{k} \text{ V/m}$
 2. $6.0 \hat{j} \text{ V/m}$
 3. $0.6 \hat{k} \text{ V/m}$
 4. $0.6 \hat{j} \text{ V/m}$

Ans: 2

Sol: $E = B \times C = 6$

Direction of wave $\parallel (\vec{E} \times \vec{B})$

$$\hat{i} = \hat{j} \times \hat{k}$$

$$\vec{E} = 6\hat{j} \text{ V/m}$$

Section B

1. A person is swimming with a speed of 10 m/s at an angle of 120° with the flow and reaches to a point directly opposite on the other side of the river. The speed of the flow is 'x' m/s. The value of 'x' to the nearest integer is _____.

Ans: 5.00

Sol:

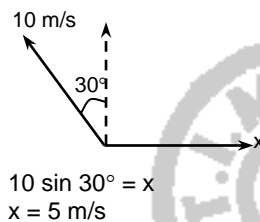

2. A parallel plate capacitor has plate area 100 m^2 and plate separation of 10 m. The space between the plates is filled up to a thickness 5 m with a material of dielectric constant of 10. The resultant capacitance of the system is 'x' pF. The value of $\epsilon_0 = 8.85 \times 10^{-12} \text{ F.m}^{-1}$. The value of 'x' to the nearest integer is _____.

Ans: 161.00

Sol: $A = 100 \text{ m}^2$

$$C = \frac{k\epsilon_0 A}{d}$$

$$C_1 = \frac{10\epsilon_0(100)}{5}$$

$$C_1 = 200 \epsilon_0$$

$$\text{||}^y C_2 = \frac{\epsilon_0(100)}{5} = 20 \epsilon_0$$

$$C_1 \text{ and } C_2 \text{ are in series } C_{\text{eq}} = \frac{C_1 C_2}{C_1 + C_2}$$

$$C_{\text{eq}} = \frac{4000\epsilon_0}{220} \\ = 160.9 \times 10^{-12} \\ \approx 161 \text{ PF}$$



3.

An npn transistor operates as a common emitter amplifier with a power gain of 10^6 . The input circuit resistance is 100Ω and the output load resistance is $10 \text{ k}\Omega$. The common emitter current gain ' β ' will be _____. (Round off to the Nearest Integer)

Ans: 100.00

Sol: $10^6 = \beta^2 \times \frac{R_0}{R_i}$

$$\left[A_p = \beta^2 \frac{R_0}{R_i} \right]$$

$$A_p = 10^6$$

$$10^6 = \beta^2 \times \frac{10^4}{10^2}$$

$$\beta^2 = 10^4$$

$$\Rightarrow \beta = 100$$

4.

A ball of mass 10 kg moving with a velocity $10\sqrt{3} \text{ m/s}$ along the x -axis, hits another ball of mass 20 kg which is at rest. After the collision, first ball comes to rest while the second ball disintegrates into two equal pieces. One piece starts moving along y -axis with a speed of 10 m/s . The second piece starts moving at an angle of 30° with respect to the x -axis.

The velocity of the ball moving at 30° with x -axis is $x \text{ m/s}$.

The configuration of pieces after collision is shown in the figure below.

The value of x to the nearest integer is _____.

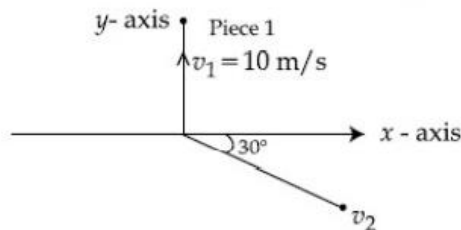

Ans: 20.00

Sol: Let velocity of second fragment is \vec{v} then by conservation of linear momentum

$$10(10\sqrt{3})\hat{i} = 10(10\hat{j}) + 10\vec{v}$$

$$\Rightarrow \vec{v} = 10\sqrt{3}\hat{i} - 10\hat{j}$$

$$|\vec{v}| = \sqrt{300 + 100} = \sqrt{400}$$

$$= 20 \text{ m/s}$$

5.

A particle performs simple harmonic motion with a period of 2 second. The time taken by the particle to cover a displacement equal to half of its amplitude from the mean position is

$$\frac{1}{a} \text{ s.}$$

The value of ' a ' to the nearest integer is _____.

Ans: 6.00

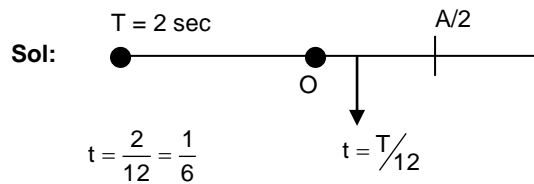

Correct answer = 6.00

Two separate wires A and B are stretched by 2 mm and 4 mm respectively, when they are subjected to a force of 2 N. Assume that both the wires are made up of same material and the radius of wire B is 4 times that of the radius of wire A. The length of the wires A and B

are in the ratio of a : b. Then $\frac{a}{b}$ can be expressed as $\frac{1}{x}$ where x is _____.

6.

Ans: 32.00

Sol: For A $\frac{E}{\pi r^2} = y \frac{2\text{mm}}{a}$ -----(1)

For B $\frac{E}{\pi 16r^2} = y \frac{4\text{mm}}{b}$ -----(2)

(1) ÷ (2) $\Rightarrow 16 = \frac{2b}{4a}$

$\frac{a}{b} = \frac{1}{32} = 32$

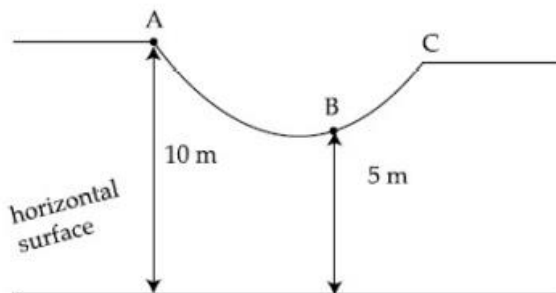

As shown in the figure, a particle of mass 10 kg is placed at a point A. When the particle is slightly displaced to its right, it starts moving and reaches the point B. The speed of the particle at B is x m/s.

(Take $g = 10 \text{ m/s}^2$)

The value of 'x' to the nearest integer is _____.

7. :-

Ans: 10.00

Sol: Using work energy theorem
 $W_g = \Delta K.E.$

$(10)(g)(5) = \frac{1}{2}(10)v^2 - 0$

$v = 10 \text{ m/s}$

8.

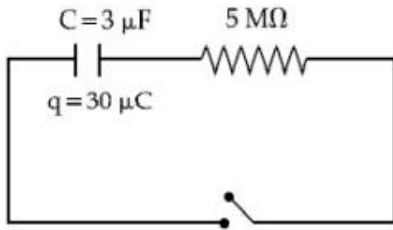

The circuit shown in the figure consists of a charged capacitor of capacity $3 \mu\text{F}$ and a charge of $30 \mu\text{C}$. At time $t=0$, when the key is closed, the value of current flowing through the $5 \text{ M}\Omega$ resistor is ' x ' μA .

The value of ' x ' to the nearest integer is _____.

Ans: 2.00

Sol: $i_0 = \frac{V}{R} = \frac{30/3}{5 \times 10^6} = 2 \times 10^{-6} = 2 \mu\text{A}$

9.

A bullet of mass 0.1 kg is fired on a wooden block to pierce through it, but it stops after moving a distance of 50 cm into it. If the velocity of bullet before hitting the wood is 10 m/s and it slows down with uniform deceleration, then the magnitude of effective retarding force on the bullet is ' x ' N .

The value of ' x ' to the nearest integer is _____.

Ans: 10.00

Sol: $V^2 = U^2 + 2as$
 $0 = 10^2 + 2(-a) \left(\frac{1}{2}\right)$
 $a = 100 \text{ m/s}^2$
 $F = ma = (0.1)(100) = 10 \text{ N}$

10.

The voltage across the 10Ω resistor in the given circuit is x volt.

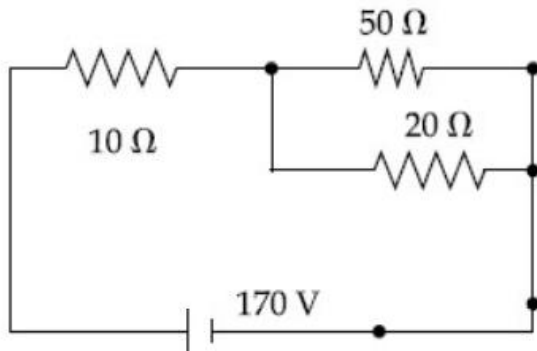

The value of ' x ' to the nearest integer is _____.

Ans: 70.00

Sol: $R_{\text{eq1}} = \frac{170}{7}$

$$V_1 = \left[\frac{170}{\frac{170}{7}} \right] \times 10 = 70 \text{ V}$$

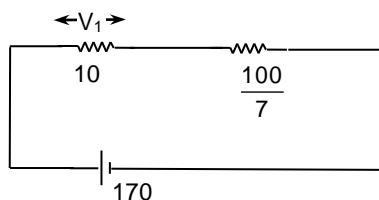

PART – B – CHEMISTRY

SECTION A

Q.1 The statements that are TRUE :

- (A) methane leads to both global warming and photochemical smog
- (B) methane is generated from paddy fields
- (C) methane is a stronger global warming gas than CO_2
- (D) methane is a part of reducing smog.

Choose the most appropriate answer from the options given below :

- Options
1. (A), (B), (C) only
 2. (B), (C), (D) only
 3. (A) and (B) only
 4. (A), (B), (D) only

Ans: 1

Sol: Methane is not a part of reducing / classical smog

Q.2 In a binary compound, atoms of element A form a hcp structure and those of element M occupy $\frac{2}{3}$ of the tetrahedral voids of the hcp structure. The formula of the binary compound is :

- Options
1. M_4A
 2. M_2A_3
 3. MA_3
 4. M_4A_3

Ans: 4

Sol: M occupy $2 \times \frac{2}{3}$ of tetrahedral void, then M_4A

Formula of the compound is M_4B_3

Q.3

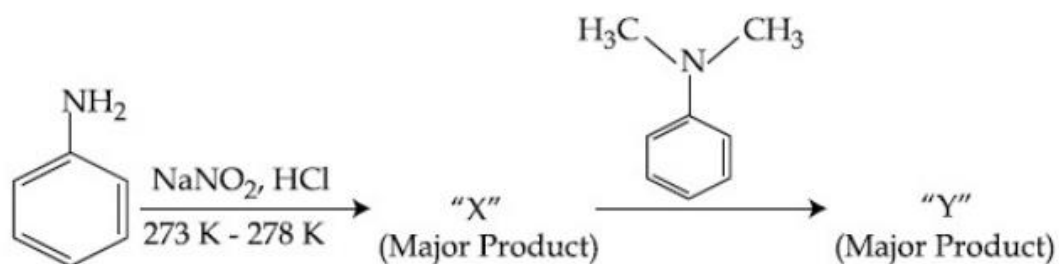

Considering the above reaction, X and Y respectively are :

Options

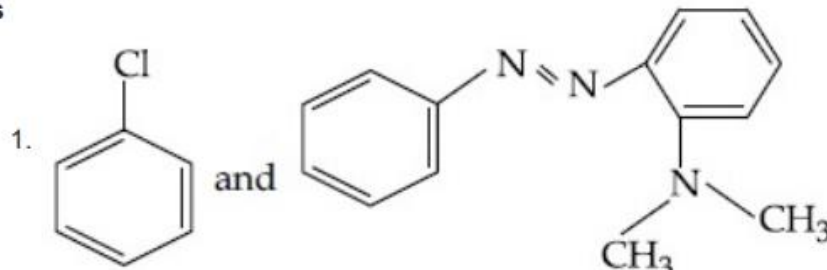
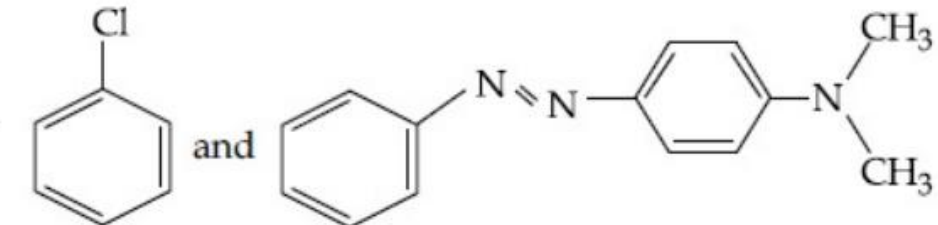
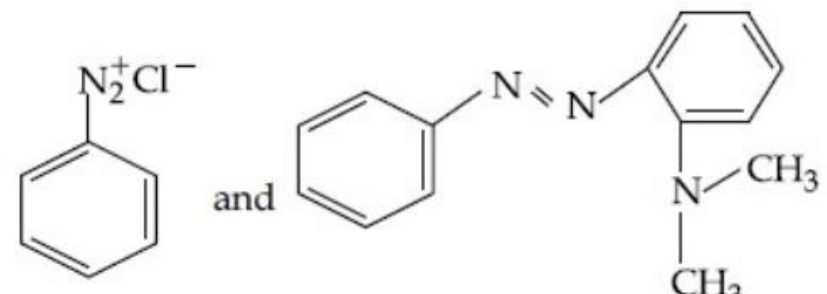
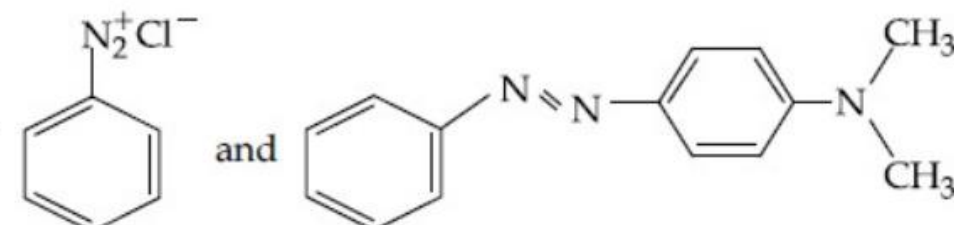
- 
- 
- 
- 

Ans: 4

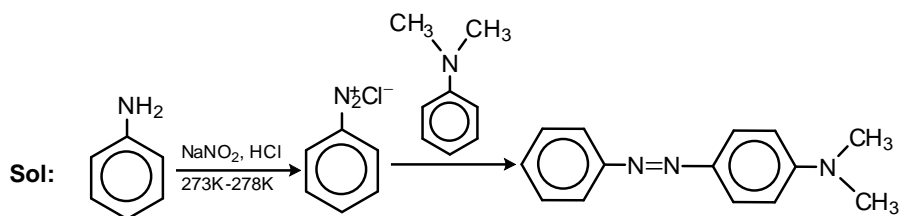

Q.4 The chemical that is added to reduce the melting point of the reaction mixture during the extraction of aluminium is :

Options 1. Cryolite

2. Kaolite

3. Bauxite

4. Calamine

Ans: 4

Sol: In the extraction of Aluminium, Na_3AlF_6 (cryolite) is added to reduce the melting point of reaction mixture

Q.5 A certain orbital has no angular nodes and two radial nodes. The orbital is :

Options 1. 2p

2. 3s

3. 2s

4. 3p

Ans: 2

Sol: Angular node = $\ell = 0$ for 's' orbital

Radial node = $n - \ell - 1$

$$= 3 - 0 - 1 = 2$$

$\therefore n = 3, \ell = 0$

\therefore 3s orbital

Q.6 Match List - I with List - II :

List - I	List - II
(a) Chlorophyll	(i) Ruthenium
(b) Vitamin - B_{12}	(ii) Platinum
(c) Anticancer drug	(iii) Cobalt
(d) Grubbs catalyst	(iv) Magnesium

Choose the most appropriate answer from the options given below :

Options 1. (a)-(iv), (b)-(iii), (c)-(i), (d)-(ii)

2. (a)-(iii), (b)-(ii), (c)-(iv), (d)-(i)

3. (a)-(iv), (b)-(ii), (c)-(iii), (d)-(i)

4. (a)-(iv), (b)-(iii), (c)-(ii), (d)-(i)

Ans: A

Sol: (a) Chlorophyll – Magnesium
(b) Vitamin B₁₂ – Cobalt
(c) Anticancer drug – Platinum
(d) Grubbs catalyst – Ruthenium

Q.7 Match List - I with List - II :

List - I	List - II
(a) Ca(OCl)_2	(i) Antacid
(b) $\text{CaSO}_4 \cdot \frac{1}{2}\text{H}_2\text{O}$	(ii) Cement
(c) CaO	(iii) Bleach
(d) CaCO_3	(iv) Plaster of Paris

Choose the most appropriate answer from the options given below :

- Options**
1. (a)-(iii), (b)-(ii), (c)-(i), (d)-(iv)
 2. (a)-(iii), (b)-(ii), (c)-(iv), (d)-(i)
 3. (a)-(i), (b)-(iv), (c)-(iii), (d)-(ii)
 4. (a)-(iii), (b)-(iv), (c)-(ii), (d)-(i)

Ans: 4

Sol: (a) Ca(OCl)_2 – Bleach
(b) $\text{CaSO}_4 \cdot \frac{1}{2}\text{H}_2\text{O}$ – Plaster of Paris
(c) CaO – Cement
(d) CaCO_3 – Antacid

Q.8 Reagent, 1-naphthylamine and sulphanilic acid in acetic acid is used for the detection of :

- Options**
1. NO_3^-
 2. NO
 3. NO_2^-
 4. N_2O

Ans: 3

Sol: Test is used for the detection of NO_2^-
 $\text{NO}_2^- + \text{CH}_3\text{COOH} \rightarrow \text{HNO}_2 + \text{CH}_3\text{COO}^-$

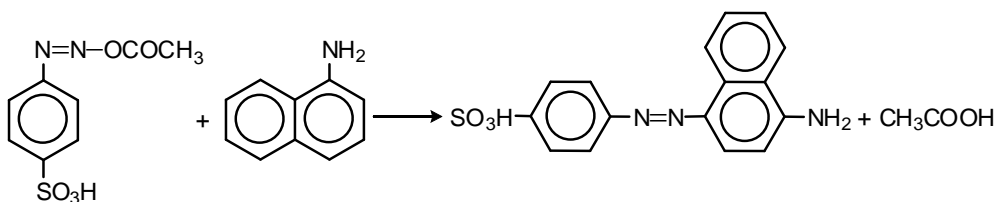
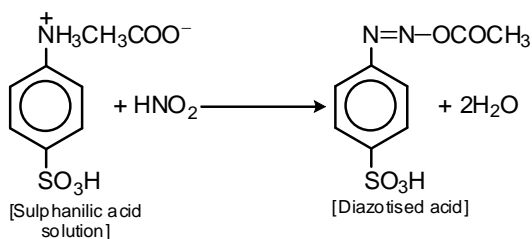

Q.9 Given below are two Statements : One is labelled as Assertion A and the other is labelled as Reason R :

Assertion A : During the boiling of water having temporary hardness, $\text{Mg}(\text{HCO}_3)_2$ is converted to MgCO_3 .

Reason R : The solubility product of $\text{Mg}(\text{OH})_2$ is greater than that of MgCO_3 .

In the light of the above statements, choose the most appropriate answer from the options given below :

- Options**
1. A is true but R is false
 2. A is false but R is true
 3. Both A and R are true and R is the correct explanation of A
 4. Both A and R are true but R is NOT the correct explanation of A

Ans: 2

Sol: $\text{Mg}(\text{HCO}_3)_2 \xrightarrow{\text{heating}} \text{Mg}(\text{OH})_2 \downarrow + 2\text{CO}_2 \uparrow$
 During boiling of water $\text{Mg}(\text{HCO}_3)_2$ get converted into $\text{Mg}(\text{OH})_2$
 The solubility product of $\text{Mg}(\text{OH})_2$ is higher than MgCO_3

Q.10

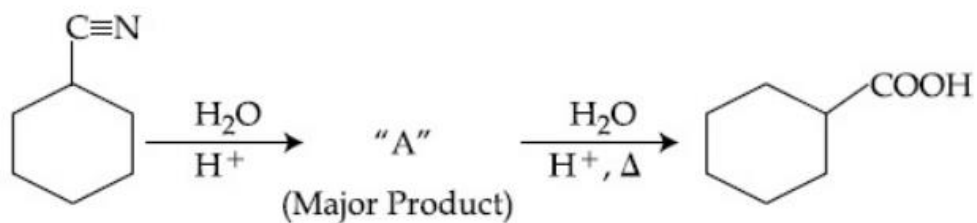

Consider the above chemical reaction and identify product "A" :

Options

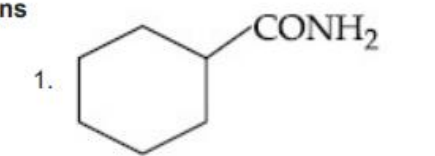
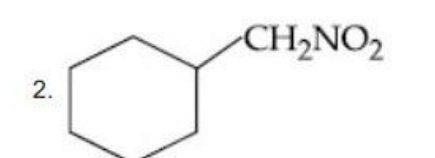
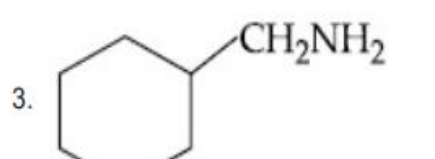
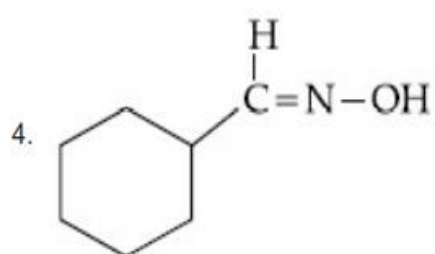
- 
- 
- 
- 

Institute of
Education Pvt. Ltd.

Ans: 1

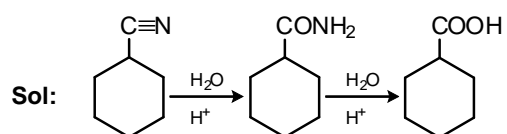

Q.11 Compound with molecular formula C_3H_6O can show :

- Options**
1. Functional group isomerism
 2. Metamerism
 3. Positional isomerism
 4. Both positional isomerism and metamerism

Ans: 1

Sol: Methoxy ethane ($CH_3-O-CH_2-CH_3$) and propanol ($CH_3-CH_2-CH_2-OH$) are functional isomers

Q.12 Match List - I with List - II :

List - I (Process)	List - II (Catalyst)
(a) Deacon's process	(i) ZSM-5
(b) Contact process	(ii) $CuCl_2$
(c) Cracking of hydrocarbons	(iii) Particles 'Ni'
(d) Hydrogenation of vegetable oils	(iv) V_2O_5

Choose the most appropriate answer from the options given below :

- Options**
1. (a)-(iii), (b)-(i), (c)-(iv), (d)-(ii)
 2. (a)-(ii), (b)-(iv), (c)-(i), (d)-(iii)
 3. (a)-(i), (b)-(iii), (c)-(ii), (d)-(iv)
 4. (a)-(iv), (b)-(ii), (c)-(i), (d)-(iii)

Ans: 2

Sol: (a) Deacon's process – $CuCl_2$
(b) Contact process – V_2O_5
(c) Cracking of hydrocarbons – ZSM-5
(d) Hydrogenation of vegetable oil – Particles 'Ni'

Q.13 Reaction of Grignard reagent, C_2H_5MgBr with C_8H_8O followed by hydrolysis gives compound "A" which reacts instantly with Lucas reagent to give compound B, $C_{10}H_{13}Cl$.
The Compound B is :

Options

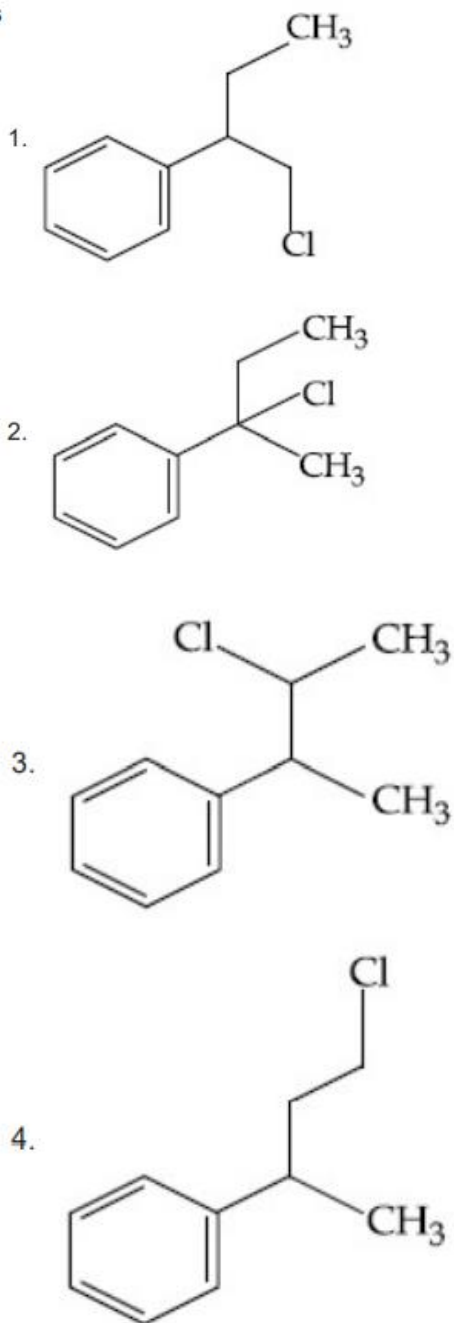

Ans: 2

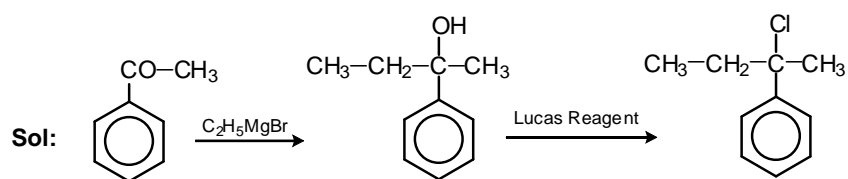

Q.14 The correct structures of $\text{trans-[NiBr}_2(\text{PPh}_3)_2]$ and meridional- $[\text{Co}(\text{NH}_3)_3(\text{NO}_2)_3]$, respectively, are :

Options

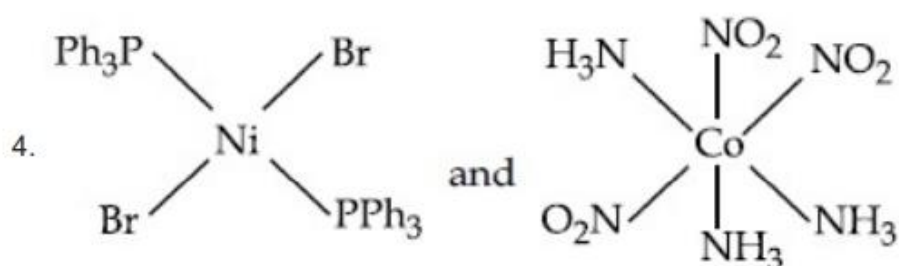
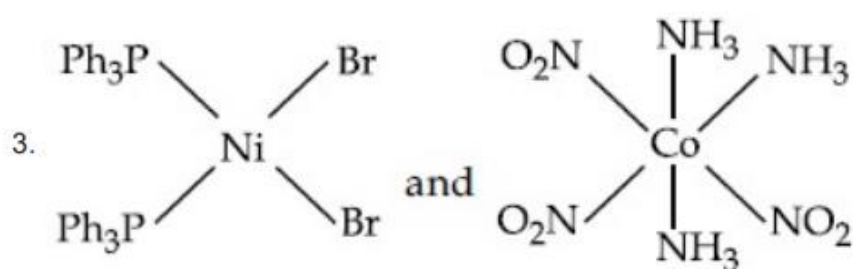
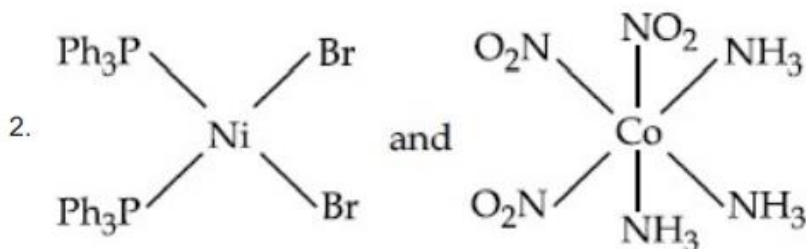
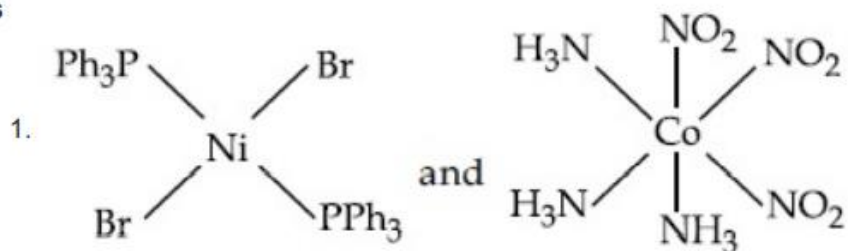

Ans: 4

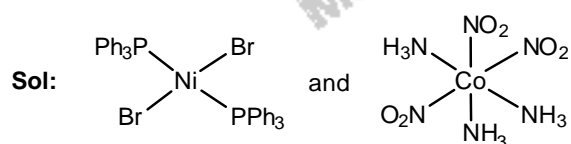

Q.15 A non-reducing sugar "A" hydrolyses to give two reducing mono saccharides. Sugar A is :

- Options**
1. Sucrose
 2. Glucose
 3. Galactose
 4. Fructose

Ans: 1

Sol: Sucrose on hydrolysis give two reducing monosaccharides, glucose and fructose

Q.16

Match List - I with List - II :

List - I		List - II	
(Class of Drug)		(Example)	
(a)	Antacid	(i)	Novestrol
(b)	Artificial Sweetener	(ii)	Cimetidine
(c)	Antifertility	(iii)	Valium
(d)	Tranquilizers	(iv)	Alitame

Choose the most appropriate match :

- Options
1. (a)-(iv), (b)-(iii), (c)-(i), (d)-(ii)
 2. (a)-(ii), (b)-(iv), (c)-(i), (d)-(iii)
 3. (a)-(iv), (b)-(i), (c)-(ii), (d)-(iii)
 4. (a)-(ii), (b)-(iv), (c)-(iii), (d)-(i)

Ans: 2

Sol: (a) Antacid – Cimetidine
(b) Artificial sweetener – Alitame
(c) Antifertility – Novestrol
(d) Tranquilizers – Valium

Q.17 The number of ionisable hydrogens present in the product obtained from a reaction of phosphorus trichloride and phosphonic acid is :

- Options
1. 3
 2. 1
 3. 0
 4. 2

Ans: 2

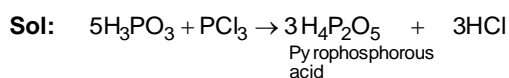

Pyrophosphorous acid is a dibasic acid

Q.18 The ionic radius of Na^+ ion is 1.02 Å. The ionic radii (in Å) of Mg^{2+} and Al^{3+} , respectively, are :

- Options**
1. 1.05 and 0.99
 2. 0.72 and 0.54
 3. 0.68 and 0.72
 4. 0.85 and 0.99

Ans: 2

Sol: For isoelectronic species, as positive charge increases, ionic radius decreases. Hence the order should be $\text{Na}^+ > \text{Mg}^{2+} > \text{Al}^{3+}$

Q.19 Match List - I with List - II :

List - I (Chemicals)	List - II (Use/Preparation/Constituent)
(a) Alcoholic potassium hydroxide	(i) electrodes in batteries
(b) Pd/BaSO ₄	(ii) obtained by addition reaction
(c) BHC (Benzene hexachloride)	(iii) used for β-elimination reaction
(d) Polyacetylene	(iv) Lindlar's Catalyst

Choose the most appropriate match :

- Options**
1. (a)-(iii), (b)-(iv), (c)-(ii), (d)-(i)
 2. (a)-(ii), (b)-(i), (c)-(iv), (d)-(iii)
 3. (a)-(ii), (b)-(iv), (c)-(i), (d)-(iii)
 4. (a)-(iii), (b)-(i), (c)-(iv), (d)-(ii)

Ans: 1

Sol:

(a) Alcoholic potassium hydroxide	–	Used for β-elimination
(b) Pd/BaSO ₄	–	Lindlar's catalyst
(c) BHC (Benzene hexa chloride)	–	Obtained by addition reaction
(d) Polyacetylene	–	Electrodes in batteries

Q.20

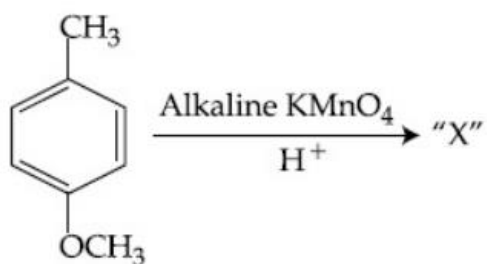

Considering the above chemical reaction, identify the product "X" :

Options

1. X -
2. X -
3. X -
4. X -

Ans: 1

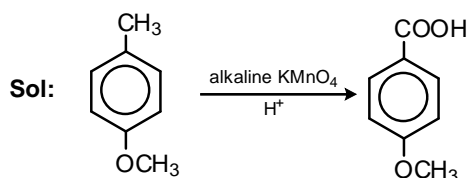

SECTION B

1. 2 molal solution of a weak acid HA has a freezing point of 3.885°C . The degree of dissociation of this acid is $\text{_____} \times 10^{-3}$. (Round off to the Nearest Integer).

[Given : Molal depression constant of water = $1.85 \text{ K kg mol}^{-1}$

Freezing point of pure water = 0°C]

Ans: 50

Sol: $\alpha = \frac{i-1}{n-1}$, Since $n = 2$, $\alpha = i - 1$ (or) $i = 1 + \alpha$

$$\Delta T_f = (1 + \alpha) K_f \cdot m$$

$$3.885 = (1 + \alpha) \times 1.85 \text{ K kg mol}^{-1} \times 2$$

$$1 + \alpha = 1.05$$

$$\alpha = 0.05 = 50 \times 10^{-3}$$

2. A reaction of 0.1 mole of Benzylamine with bromomethane gave 23 g of Benzyl trimethyl ammonium bromide. The number of moles of bromomethane consumed in this reaction are $n \times 10^{-1}$, when $n = \text{_____}$. (Round off to the Nearest Integer).

[Given : Atomic masses : C : 12.0 u, H : 1.0 u, N : 14.0 u, Br : 80.0 u]

Ans: 3

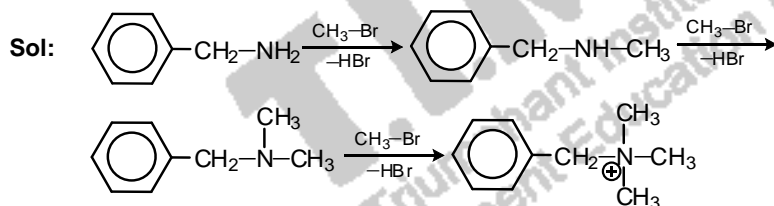

1 mole benzyl amine reacts with 3 moles of $\text{CH}_3\text{-Br}$ to form Benzyl trimethyl ammonium bromide

\therefore 0.1 mole benzyl amine reacts with 3×10^{-1} moles of CH_3Br

3. _____ grams of 3-Hydroxy propanal (MW = 74) must be dehydrated to produce 7.8 g of acrolein (MW = 56) ($\text{C}_3\text{H}_4\text{O}$) if the percentage yield is 64. (Round off to the Nearest Integer).

[Given : Atomic masses : C : 12.0 u, H : 1.0 u, O : 16.0 u]

Ans: 16

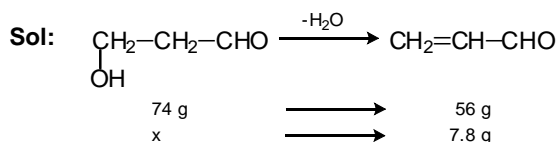

If the percentage yield is 64, then the number of grams of 3-hydroxy propanal dehydrated

$$= \frac{74 \times 7.8}{56} \times \frac{100}{64} = 16.10 \text{ g}$$

4. AX is a covalent diatomic molecule where A and X are second row elements of periodic table. Based on Molecular orbital theory, the bond order of AX is 2.5. The total number of electrons in AX is _____. (Round off to the Nearest Integer).

Ans: 15

Sol: The diatomic molecule is NO which contains 15 electrons. Based on molecular orbital theory, the bond order of NO is 2.5

5. For the reaction

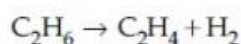

the reaction enthalpy $\Delta_r H =$ _____ kJ mol^{-1} . (Round off to the Nearest Integer).

[Given : Bond enthalpies in kJ mol^{-1} : C-C : 347, C=C : 611;

C-H : 414, H-H : 436]

Ans: 128

Sol: $\Delta H_r^\circ = [6\Delta H_{\text{C-H}} + \Delta H_{\text{C-C}}] - [\Delta H_{\text{C=C}} + 4\Delta H_{\text{C-H}} + \Delta H_{\text{H-H}}]$
 $= [6 \times 414 + 347] - [611 + 4 \times 414 + 436] = 128$

6. The total number of unpaired electrons present in the complex $\text{K}_3[\text{Cr}(\text{oxalate})_3]$ is _____.

Ans: 3

Sol: In $\text{K}_3[\text{Cr}(\text{oxalate})_3]$
 Oxidation state of Cr in the complex is +3
 $\text{Cr} = [\text{Ar}] 3d^5 4s^1$
 $\text{Cr}^{3+} = [\text{Ar}] 3d^3$
 Number of unpaired electrons = 3

7. Complete combustion of 3 g of ethane gives $x \times 10^{22}$ molecules of water. The value of x is _____ (Round off to the Nearest Integer).

[Use : $N_A = 6.023 \times 10^{23}$; Atomic masses in u : C : 12.0 ; O : 16.0 ; H : 1.0]

Ans: 3

Sol: $\text{C}_2\text{H}_6 + \frac{7}{2} \text{O}_2 \rightarrow 2\text{CO}_2 + 3\text{H}_2\text{O}$

30 g ethane $\rightarrow 3 \times 6.022 \times 10^{23}$ H_2O molecules
 \therefore 3 g ethane $\rightarrow 3 \times 6.022 \times 10^{22}$ H_2O molecules

8. For the reaction

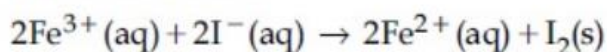

the magnitude of the standard molar free energy change,

$$\Delta_r G_m^\circ = - \text{_____ kJ (Round off to the Nearest Integer).}$$

$$\left[\begin{array}{l} E^\circ_{\text{Fe}^{2+}/\text{Fe}(\text{s})} = -0.440 \text{ V}; E^\circ_{\text{Fe}^{3+}/\text{Fe}(\text{s})} = -0.036 \text{ V} \\ E^\circ_{\text{I}_2/2\text{I}^{-}} = 0.539 \text{ V}; \quad F = 96500 \text{ C} \end{array} \right]$$

Ans: 45

Sol: $\Delta G^\circ = -nFE^\circ_{\text{cell}}$

$$E^\circ_{\text{cell}} = E^\circ_{\text{Fe}^{3+}/\text{Fe}^{2+}} - E^\circ_{\text{I}_2/\text{I}^{-}}$$

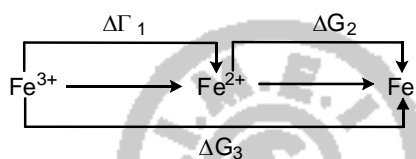

$$\Delta G_1 + \Delta G_2 = \Delta G_3$$

$$E^\circ [E^\circ_{\text{Fe}^{3+}/\text{Fe}^{2+}}] + 2E^\circ [\text{Fe}^{2+}/\text{Fe}] = 3E^\circ [\text{Fe}^{3+}/\text{Fe}]$$

$$\therefore E^\circ (\text{Fe}^{3+}/\text{Fe}^{2+}) = 3[-0.036] - 2[-0.440 \text{ V}] = +0.772 \text{ V}$$

$$E^\circ_{\text{cell}} = (E^\circ_{\text{Fe}^{3+}/\text{Fe}^{2+}}) - (E^\circ_{\text{I}_2/\text{I}^{-}}) = 0.772 - 0.539 = 0.233 \text{ V}$$

$$\Delta G^\circ = -nFE^\circ_{\text{cell}}$$

$$= -2 \times 96500 \times 10^{-3} \times 0.233 = -44.92 \text{ kJ} \approx 45 \text{ kJ}$$

9. $2\text{NO}(\text{g}) + \text{Cl}_2(\text{g}) \rightleftharpoons 2\text{NOCl}(\text{s})$

This reaction was studied at -10°C and the following data was obtained

run	$[\text{NO}]_0$	$[\text{Cl}_2]_0$	r_0
1	0.10	0.10	0.18
2	0.10	0.20	0.35
3	0.20	0.20	1.40

$[\text{NO}]_0$ and $[\text{Cl}_2]_0$ are the initial concentrations and r_0 is the initial reaction rate.

The overall order of the reaction is _____. (Round off to the Nearest Integer).

Ans: 3

Sol: Rate = $k[\text{NO}]^x [\text{Cl}_2]^y$

$$0.18 = k[0.10]^x [0.10]^y \text{ ---- (1)}$$

$$0.35 = k[0.10]^x [0.20]^y \text{ ---- (2)}$$

Divide eq (2) by eq (1)

$$2 = 2^y$$

$$\therefore y = 1$$

$$0.35 = k[0.10]^x [0.20]^y \text{ ---- (3)}$$

$$1.40 = k[0.20]^x [0.20]^y \text{ ---- (4)}$$

$$4 = 2^x$$

$$\therefore x = 2$$

$$\text{Overall order of reaction } x + y = 2 + 1 = 3$$

10. In order to prepare a buffer solution of pH 5.74, sodium acetate is added to acetic acid. If the concentration of acetic acid in the buffer is 1.0 M, the concentration of sodium acetate in the buffer is _____ M. (Round off to the Nearest Integer).

[Given : pKa (acetic acid) = 4.74]

Ans: 10

Sol: $\text{pH} = \text{pK}_a + \log \frac{[\text{Conjugate base}]}{[\text{Acid}]}$
 $5.74 = 4.74 + \log \frac{[\text{Conjugate base}]}{1}$
 $\log [\text{conjugate base}] = 1$
 $[\text{conjugate base}] = \text{antilog}(1) = 10$

PART – C – MATHEMATICS

SECTION A

1.

Q.1 The differential equation satisfied by the system of parabolas $y^2 = 4a(x + a)$ is :

Options

1. $y \left(\frac{dy}{dx} \right) + 2x \left(\frac{dy}{dx} \right) - y = 0$

2. $y \left(\frac{dy}{dx} \right)^2 - 2x \left(\frac{dy}{dx} \right) - y = 0$

3. $y \left(\frac{dy}{dx} \right)^2 - 2x \left(\frac{dy}{dx} \right) + y = 0$

4. $y \left(\frac{dy}{dx} \right)^2 + 2x \left(\frac{dy}{dx} \right) - y = 0$

Ans: 4

Sol: $y^2 = 4a(x + a)$

$$2yy' = 4a \cdot 1 \Rightarrow a = \frac{1}{2}yy'$$

$$\therefore y^2 = 2yy' \left[x + \frac{1}{2}yy' \right] = 2xyy' + (yy')^2$$

$$\Rightarrow y(y')^2 + 2xy' - y = 0$$

Q.2

The value of $3 + \frac{1}{4 + \frac{1}{3 + \frac{1}{4 + \frac{1}{3 + \dots \infty}}}}$ is equal to :

- Options
1. $2 + \sqrt{3}$
 2. $3 + 2\sqrt{3}$
 3. $4 + \sqrt{3}$
 4. $1.5 + \sqrt{3}$

Ans: 4

Sol: $x = 3 + \frac{1}{4 + \left(3 + \frac{1}{4 + \frac{1}{3 + \dots}} \right)}$

$$\Rightarrow x = 3 + \frac{1}{4 + \frac{1}{x}} = 3 + \frac{1}{\frac{4x+1}{x}} = 3 + \frac{x}{4x+1}$$

$$\Rightarrow x - 3 = \frac{x}{4x+1} \Rightarrow 4x^2 + x - 12x - 3 - x = 0$$

$$4x^2 - 12x - 3 = 0$$

$$x = \frac{12 \pm \sqrt{144 + 48}}{8} = \frac{12 \pm 8\sqrt{3}}{8} = 1.5 + \sqrt{3} \quad (\because x > 0)$$

Q.3 If α, β are natural numbers such that $100^\alpha - 199\beta = (100)(100) + (99)(101) + (98)(102) + \dots + (1)(199)$, then the slope of the line passing through (α, β) and origin is :

- Options
1. 550
 2. 540
 3. 530
 4. 510

Ans: 1

Sol: $100^2 + (99)(101) + (98)(102) + \dots + (1)(199)$

$$= 100^2(100 - 1)(100 + 1) + (100 - 2)(100 + 2)$$

$$+ \dots + (100 - 99)(100 + 99)$$

$$= 100^2 + (100^2 - 1^2) + (100^2 - 2^2) + \dots + (100^2 - 99^2)$$

$$= 100^2(100) - (1^2 + 2^2 + \dots + 99^2)$$

$$= 100^3 - \frac{(99)(100)(199)}{2} \quad \left[\because 1^2 + 2^2 + 3^2 + \dots + n^2 = \frac{n(n+1)(2n+1)}{6} \right]$$

$$= 100^3 - 199(1650)$$

$$\therefore \alpha = 3, \beta = 1650$$

$$\text{Slope} = \frac{1650 - 0}{3 - 0} = 550$$

Q.4 For the four circles M, N, O and P, following four equations are given :

Circle M : $x^2 + y^2 = 1$

Circle N : $x^2 + y^2 - 2x = 0$

Circle O : $x^2 + y^2 - 2x - 2y + 1 = 0$

Circle P : $x^2 + y^2 - 2y = 0$

If the centre of circle M is joined with centre of the circle N, further centre of circle N is joined with centre of the circle O, centre of circle O is joined with the centre of circle P and lastly, centre of circle P is joined with centre of circle M, then these lines form the sides of a :

- Options**
1. Parallelogram
 2. Square
 3. Rectangle
 4. Rhombus

Ans: 2

Sol: Centre of M : (0, 0) (A)
 Centre of N : (1, 0) (B)
 Centre of O : (1, 1) (C)
 Centre of P : (0, 1) (D)

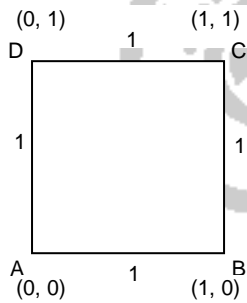

Clearly ABCD is a square

Q.5 The sum of all the 4-digit distinct numbers that can be formed with the digits 1, 2, 2 and 3 is :

- Options**
1. 22264
 2. 122664
 3. 122234
 4. 26664

Ans: 4

Sol: Sum of all 'n' distinct numbers that can be formed using distinct digit x_1, x_2, \dots, x_n is $(n-1)! \times 1111 \dots 1 \times (x_1 + x_2 + \dots + x_n)$ (n digits)

The given digits : 1, 2, 2, 3

If we consider the digits 2 and 2 are different objects

$$\text{Sum} = (4-1)! \times 1111 \times (1 + 2 + 2 + 3) = 3! \times 1111 \times 8$$

$$\text{The required sum (i.e., '2' and '2' are same objects)} = \frac{3! \times 1111 \times 8}{2} = 26664$$

Q.6 The solutions of the equation

$$\begin{vmatrix} 1 + \sin^2 x & \sin^2 x & \sin^2 x \\ \cos^2 x & 1 + \cos^2 x & \cos^2 x \\ 4 \sin 2x & 4 \sin 2x & 1 + 4 \sin 2x \end{vmatrix} = 0, (0 < x < \pi), \text{ are :}$$

Options

1. $\frac{7\pi}{12}, \frac{11\pi}{12}$

2. $\frac{\pi}{6}, \frac{5\pi}{6}$

3. $\frac{\pi}{12}, \frac{\pi}{6}$

4. $\frac{5\pi}{12}, \frac{7\pi}{12}$

Ans: 1

Sol: $R_1 \rightarrow R_1 + R_2$

$$\Rightarrow \begin{vmatrix} 2 & 2 & 1 \\ \cos^2 x & 1 + \cos^2 x & \cos^2 x \\ 4 \sin 2x & 4 \sin 2x & 1 + 4 \sin 2x \end{vmatrix} \quad \begin{array}{l} C_3 \rightarrow C_3 - C_2 \\ C_2 \rightarrow C_2 - C_1 \end{array}$$

$$\Rightarrow \begin{vmatrix} 2 & 0 & -1 \\ \cos^2 x & 1 & 1 \\ 4 \sin 2x & 0 & 1 \end{vmatrix} = 2(1-0) - 1(0-4 \sin 2x)$$

$$= 2 + 4 \sin 2x = 0 \Rightarrow \sin 2x = \frac{-1}{2}$$

$$2x = 180 + 30, 360 - 30, 360 + 180 + 30 \text{ etc}$$

$$\Rightarrow x = 90 + 15, 180 - 15 \quad (\because x \in (0, \pi))$$

$$\Rightarrow x = \frac{7\pi}{12}, \frac{11\pi}{12}$$

Q.7 If the equation $a|z|^2 + \overline{\alpha z + \alpha \bar{z}} + d = 0$ represents a circle where a, d are real constants, then which of the following condition is correct ?

Options

1. $\alpha = 0, a, d \in \mathbb{R}^+$

2. $|\alpha|^2 - ad \neq 0$

3. $|\alpha|^2 - ad \geq 0$ and $a \in \mathbb{R}$

4. $|\alpha|^2 - ad > 0$ and $a \in \mathbb{R} - \{0\}$

Ans: 4

Sol: $a|z|^2 + (\overline{\alpha z + \alpha \bar{z}}) + d = 0$

$$\Rightarrow a|z|^2 + (\overline{\alpha z}) + (\overline{\alpha \bar{z}}) + d = 0$$

$$\Rightarrow a|z|^2 + \alpha \bar{z} + \bar{\alpha} z + d = 0$$

Let $\alpha = p + iq$ and $z = x + iy$

$$\Rightarrow a(x^2 + y^2) + (p + iq)(x - iy) + (p - iq)(x + iy) + d = 0$$

$$\Rightarrow a(x^2 + y^2) + 2px + 2qy + d = 0$$

$$\Rightarrow x^2 + y^2 + \frac{2p}{a}x + \frac{2q}{a}y + \frac{d}{a} = 0$$

$$g^2 + f^2 - c > 0 \Rightarrow \frac{p^2}{a^2} + \frac{q^2}{a^2} - \frac{d}{a} > 0$$

$$p^2 + q^2 - ad > 0$$

$$\Rightarrow |\alpha|^2 - ad > 0, a \in \mathbb{R} - \{0\}$$

Q.8 Let $(1 + x + 2x^2)^{20} = a_0 + a_1x + a_2x^2 + \dots + a_{40}x^{40}$. Then, $a_1 + a_3 + a_5 + \dots + a_{37}$ is equal to :

- Options**
1. $2^{20}(2^{20} - 21)$
 2. $2^{19}(2^{20} - 21)$
 3. $2^{20}(2^{20} + 21)$
 4. $2^{19}(2^{20} + 21)$

Ans: 2

Sol: $(1 + x + 2x^2)^{20} = a_0 + a_1x + a_2x^2 + \dots + a_{39}x^{39} + a_{40}x^{40}$ ---- (1)

To find a_{39}

$$[2x^2 + (1 + x)]^{20} = (2x^2)^{20} + {}^{20}C_1 (2x^2)^{19} \cdot (1 + x) + {}^{20}C_2 (2x^2)^{18} \cdot (1 + x)^2 + \dots$$

Coeff of $x^{39} = {}^{20}C_1 \cdot 2^{19}$ [No other terms contains x^{39}]

Put $x = 1$ in (1), $4^{20} = a_0 + a_1 + a_2 + \dots + a_{39} + a_{40}$ ---- (A)

Put $x = -1$ in (1), $2^{20} = a_0 - a_1 + a_2 - a_3 + \dots + a_{39} + a_{40}$ ---- (B)

$$(A) - (B) \Rightarrow 2a_1 + 2a_3 + 2a_5 + \dots + 2a_{37} + 2a_{39} = 4^{20} - 2^{20} = 2^{40} - 2^{20}$$

$$\Rightarrow a_1 + a_3 + a_5 + \dots + a_{37} + a_{39} = 2^{39} - 2^{19}$$

$$\therefore a_1 + a_3 + a_5 + \dots + a_{37} + a_{39} = 2^{39} - 2^{19} - 2^{39}$$

$$= 2^{39} - 2^{19} - 20 \cdot 2^{19} = 2^{39} - 21 \cdot 2^{19}$$

$$= 2^{19}(2^{20} - 21)$$

Q.9 The real valued function $f(x) = \frac{\operatorname{cosec}^{-1}x}{\sqrt{x - [x]}}$, where $[x]$ denotes the greatest integer less than or

equal to x , is defined for all x belonging to :

- Options**
1. all non-integers except the interval $[-1, 1]$
 2. all reals except the interval $[-1, 1]$
 3. all reals except integers
 4. all integers except 0, $-1, 1$

Ans: 1

Sol: $y = \frac{\operatorname{cosec}^{-1}x}{\sqrt{x - [x]}}$

If $x \in \mathbb{N}$, $x - [x] = 0$ then y is not defined

$\operatorname{cosec}^{-1}x$ is defined if $f \in (\infty, -1] \cup [1, \infty)$

Q.10

If $f(x) = \begin{cases} \frac{1}{x} & ; |x| \geq 1 \\ ax^2 + b & ; |x| < 1 \end{cases}$ is differentiable at every point of the domain, then the values of

a and b are respectively :

Options

1. $-\frac{1}{2}, \frac{3}{2}$

2. $\frac{1}{2}, -\frac{3}{2}$

3. $\frac{5}{2}, -\frac{3}{2}$

4. $\frac{1}{2}, \frac{1}{2}$

Ans: 1

Sol: $f(x) = \begin{cases} \frac{1}{x} & ; |x| \geq 1 \\ ax^2 + b & ; |x| < 1 \end{cases}$

$$= \begin{cases} \frac{1}{|x|} & \text{if } x \in (\infty, -1) \cup [1, \infty) \\ ax^2 + b & \text{if } -1 < x < 1 \end{cases}$$
$$= \begin{cases} \frac{1}{x} & \text{if } x \geq 1 \\ \frac{-1}{x} & \text{if } x \leq -1 \\ ax^2 + b & \text{if } -1 < x < 1 \end{cases}$$
$$= \begin{cases} \frac{-1}{x} & \text{if } x \leq -1 \\ ax^2 + b & \text{if } -1 < x < 1 \\ \frac{1}{x} & \text{if } x \geq 1 \end{cases}$$

$$\lim_{x \rightarrow -1^-} f(x) = \lim_{x \rightarrow -1^-} \left(\frac{-1}{x} \right) = \frac{-1}{-1} = 1$$

$$\lim_{x \rightarrow -1^+} f(x) = \lim_{x \rightarrow -1^+} (ax^2 + b) = a + b$$

$$\Rightarrow a + b = 1$$

$$\left(\frac{dy}{dx} \right)_{(x=-1^-)} = \frac{d}{dx} \left(\frac{-1}{x} \right) \Big|_{x=-1^-}$$

$$= \left(\frac{1}{x^2} \right)_{x=-1^-} = \frac{1}{1} = 1$$

$$\left(\frac{dy}{dx} \right)_{x=-1^+} = \frac{dy}{dx} (ax^2 - b) \Big|_{x=-1^+} = (2ax)_{x=-1^+} = -2a$$

$$\therefore -2a = 1 \Rightarrow a = \frac{-1}{2}$$

$$\therefore \frac{-1}{2} + b = 1 \Rightarrow b = \frac{3}{2}$$

Q.11 Let α, β, γ be the real roots of the equation, $x^3 + ax^2 + bx + c = 0$, ($a, b, c \in \mathbb{R}$ and $a, b \neq 0$). If the system of equations (in u, v, w) given by $\alpha u + \beta v + \gamma w = 0$; $\beta u + \gamma v + \alpha w = 0$;

$\gamma u + \alpha v + \beta w = 0$ has non-trivial solution, then the value of $\frac{a^2}{b}$ is :

Options 1. 3

2. 5

3. 0

4. 1

Ans: 1

Sol: $x^3 + ax^2 + bx + c = 0$

$$\Rightarrow \alpha + \beta + \gamma = -a$$

$$\alpha\beta + \beta\gamma + \alpha\gamma = b$$

$$\alpha\beta\gamma = -c$$

$$\begin{vmatrix} \alpha & \beta & \gamma \\ \beta & \gamma & \alpha \\ \gamma & \alpha & \beta \end{vmatrix} = 0, C_1 \rightarrow C_1 + C_2 + C_3$$

$$\Rightarrow (\alpha + \beta + \gamma) \begin{vmatrix} 1 & \beta & \gamma \\ 1 & \gamma & \alpha \\ 1 & \alpha & \beta \end{vmatrix} = 0$$

$$\begin{aligned} &\Rightarrow -a[(\alpha\beta + \beta\gamma + 2\alpha\gamma) - (\alpha^2 + \beta^2 + \gamma^2)] \\ &= -a[b - \{(\alpha + \beta + \gamma)^2 - 2(\alpha\beta + \beta\gamma + \alpha\gamma)\}] \\ &= -a[b - (a^2 - 2b)] = -a(b - a^2 + 2b) \\ &= a(3b - a^2) = a^3 - 3ab = 0 \end{aligned}$$

$$\Rightarrow a^3 = 3ab \Rightarrow a^2 = 3b \Rightarrow \frac{a^2}{b} = 3$$

Q.12 If $\lim_{x \rightarrow 0} \frac{\sin^{-1} x - \tan^{-1} x}{3x^3}$ is equal to L, then the value of $(6L + 1)$ is :

Options 1. 2

2. $\frac{1}{2}$

3. 6

4. $\frac{1}{6}$

Ans: 1

Sol:
$$\lim_{x \rightarrow 0} \left[\frac{\sin^{-1} x - \tan^{-1} x}{3x^3} \right] = \lim_{x \rightarrow 0} \left[\frac{(1-x^2)^{-1/2} - (1+x^2)^{-1}}{9x^2} \right]$$

$$= \lim_{x \rightarrow 0} \left[\frac{\left(1 + \frac{1}{2}x^2 + \frac{3}{2}x^4 + \dots \right) - (1 - x^2 + x^4 - \dots)}{9x^2} \right]$$

$\therefore (1+x)^n = 1 + nx + \frac{n(n-1)}{1.2}x^2 + \dots + \text{to } \infty \text{ if } x \notin \mathbb{N}$

$$= \lim_{x \rightarrow 0} \left[\frac{\frac{3}{2}x^2 + \text{higher powers of } x}{9x^2} \right] = \frac{3/2}{9} = \frac{1}{6}, 6L + 1 = 2$$

Q.13 The equation of one of the straight lines which passes through the point (1, 3) and makes an angle $\tan^{-1}(\sqrt{2})$ with the straight line, $y + 1 = 3\sqrt{2}x$ is :

- Options**
1. $5\sqrt{2}x + 4y - (15 + 4\sqrt{2}) = 0$
 2. $4\sqrt{2}x - 5y - (5 + 4\sqrt{2}) = 0$
 3. $4\sqrt{2}x + 5y - (15 + 4\sqrt{2}) = 0$
 4. $4\sqrt{2}x + 5y - 4\sqrt{2} = 0$

Ans: 3

Sol:

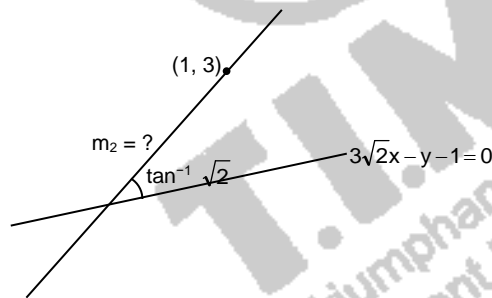

$$\left| \frac{m_2 - m_1}{1 + m_1 m_2} \right| = \tan [\tan^{-1} \sqrt{2}] = \sqrt{2}$$

$$\frac{m_2 - 3\sqrt{2}}{1 + 3\sqrt{2}m_2} = \pm \sqrt{2}$$

$$m_2 - 3\sqrt{2} = \sqrt{2} + 6m_2$$

$$\Rightarrow 5m_2 = -4\sqrt{2} \Rightarrow m_2 = \frac{-4\sqrt{2}}{5}$$

Equation of the line

$$y - 3 = \frac{-4\sqrt{2}}{5}(x - 1)$$

$$\Rightarrow 5y - 15 = -4\sqrt{2}x + 4\sqrt{2}$$

$$4\sqrt{2}x + 5y - (15 + 4\sqrt{2}) = 0$$

Q.14

The integral $\int \frac{(2x-1)\cos\sqrt{(2x-1)^2+5}}{\sqrt{4x^2-4x+6}} dx$ is equal to :

(where c is a constant of integration)

Options

1. $\frac{1}{2}\cos\sqrt{(2x-1)^2+5} + c$

2. $\frac{1}{2}\cos\sqrt{(2x+1)^2+5} + c$

3. $\frac{1}{2}\sin\sqrt{(2x+1)^2+5} + c$

4. $\frac{1}{2}\sin\sqrt{(2x-1)^2+5} + c$

Ans: 4

Sol: Let $\sqrt{2(x-1)^2+5} = t$
 $\Rightarrow \frac{1(4)(2x-1)dx}{2\sqrt{4x^2-4x+6}} = dt$
 $\Rightarrow \frac{(2x-1)}{\sqrt{4x^2-4x+6}} dx = \frac{1}{2} dt$
The given integral $= \frac{1}{2} \int \cos t \cdot dt = \frac{1}{2} \sin t + c$

Q.15 A vector \vec{a} has components $3p$ and 1 with respect to a rectangular cartesian system. This system is rotated through a certain angle about the origin in the counter clockwise sense. If, with respect to new system, \vec{a} has components $p+1$ and $\sqrt{10}$, then a value of p is equal to :

Options

1. $-\frac{5}{4}$

2. -1

3. $\frac{4}{5}$

4. 1

Ans: 2

Sol: $|\vec{a}|$ before rotation $= |\vec{a}|$ after rotation
 $\Rightarrow \sqrt{9p^2+1} = \sqrt{(p+1)^2+10}$
 $\Rightarrow 9p^2+1 = p^2+2p+11 \Rightarrow 8p^2-2p-10 = 0$
 $\Rightarrow 4p^2-p-5 = 0 \Rightarrow p = \frac{1 \pm \sqrt{1+80}}{8} = \frac{1 \pm 9}{8} = \frac{5}{4}$ or -1

Q.16 Choose the correct statement about two circles whose equations are given below :

$$x^2 + y^2 - 10x - 10y + 41 = 0$$

$$x^2 + y^2 - 22x - 10y + 137 = 0$$

- Options**
1. circles have no meeting point
 2. circles have only one meeting point
 3. circles have two meeting points
 4. circles have same centre

Ans: 2

Sol: $C_1: (5, 5), r_1 = \sqrt{25 + 25 - 41} = 3$

$$C_2: (11, 5), r_2 = \sqrt{121 + 25 - 137} = 3$$

$$C_1C_2 = \sqrt{(5 - 11)^2 + (5 - 5)^2} = 6$$

$$C_1C_2 = r_1 + r_2$$

The two circles touch externally

Q.17 $\frac{1}{3^2 - 1} + \frac{1}{5^2 - 1} + \frac{1}{7^2 - 1} + \dots + \frac{1}{(201)^2 - 1}$ is equal to :

- Options**
1. $\frac{101}{404}$
 2. $\frac{25}{101}$
 3. $\frac{101}{408}$
 4. $\frac{99}{400}$

Ans: 2

Sol: Using the property $a^2 - b^2 = (a - b)(a + b)$, the given

$$\text{Series} = \frac{1}{2 \cdot 4} + \frac{1}{4 \cdot 6} + \frac{1}{6 \cdot 8} + \frac{1}{8 \cdot 10} + \dots + \frac{1}{200 \cdot 202}$$

$$= \frac{1}{2} \left[\left(\frac{1}{2} - \frac{1}{4} \right) + \left(\frac{1}{4} - \frac{1}{6} \right) + \left(\frac{1}{6} - \frac{1}{8} \right) + \left(\frac{1}{8} - \frac{1}{10} \right) + \dots + \left(\frac{1}{200} - \frac{1}{202} \right) \right]$$

$$= \frac{1}{2} \left[\frac{1}{2} - \frac{1}{202} \right] = \frac{1}{2} \cdot \frac{100}{202} = \frac{50}{202} = \frac{25}{101}$$

Q.18 The number of integral values of m so that the abscissa of point of intersection of lines $3x + 4y = 9$ and $y = mx + 1$ is also an integer, is :

- Options**
1. 0
 2. 2
 3. 3
 4. 1

Ans: 2

Sol: $3x + 4y = 9, y = mx + 1$
 $\Rightarrow 3x + 4(mx + 1) = 9 \Rightarrow (3 + 4m)x = 5$
 $\Rightarrow x = \frac{5}{3 + 4m}$ is an integer
 $\Rightarrow m = -1, -2$

Q.19 If the functions are defined as $f(x) = \sqrt{x}$ and $g(x) = \sqrt{1-x}$, then what is the common domain of the following functions : $f+g, f-g, f/g, g/f, g-f$ where

$$(f \pm g)(x) = f(x) \pm g(x), (f/g)(x) = \frac{f(x)}{g(x)}$$

- Options**
1. $0 \leq x \leq 1$
 2. $0 < x < 1$
 3. $0 < x \leq 1$
 4. $0 \leq x < 1$

Ans: 2

Sol: $f(x) = \sqrt{x}, g(x) = \sqrt{1-x}$
 $\text{Dom } f = [0, \infty)$ and $\text{Dom } g = (-\infty, 1]$
 $\text{Dom } f \cap \text{Dom } g = [0, 1]$ but $x \neq 0$ and $x \neq 1$
 As $\frac{f}{g}$ and $\frac{g}{f}$ are to be defined (\because Denominator $\neq 0$)
 $\therefore 0 < x < 1$

Q.20 Let $A + 2B = \begin{bmatrix} 1 & 2 & 0 \\ 6 & -3 & 3 \\ -5 & 3 & 1 \end{bmatrix}$ and $2A - B = \begin{bmatrix} 2 & -1 & 5 \\ 2 & -1 & 6 \\ 0 & 1 & 2 \end{bmatrix}$. If $\text{Tr}(A)$ denotes the sum of all

diagonal elements of the matrix A , then $\text{Tr}(A) - \text{Tr}(B)$ has value equal to :

- Options**
1. 0
 2. 2
 3. 1
 4. 3

Ans: 2

$$\text{Sol: } A + 2B = \begin{bmatrix} 1 & 2 & 0 \\ 6 & -3 & 3 \\ -5 & 3 & 1 \end{bmatrix} \text{---(1)}$$

$$2A - B = \begin{bmatrix} 2 & -1 & 5 \\ 2 & -1 & 6 \\ 0 & 1 & 2 \end{bmatrix} \text{----(2)}$$

$$2 \times (1) - (2) \Rightarrow 5B = \begin{bmatrix} 0 & 5 & 5 \\ 10 & -5 & 0 \\ -10 & 5 & 0 \end{bmatrix}$$

$$\Rightarrow B = \begin{bmatrix} 0 & 1 & 1 \\ 2 & -1 & 0 \\ -2 & 1 & 0 \end{bmatrix}$$

$$(1) \Rightarrow A + \begin{bmatrix} 0 & 2 & -2 \\ 4 & -2 & 0 \\ -4 & 2 & 0 \end{bmatrix} = \begin{bmatrix} 1 & 2 & 0 \\ 6 & -3 & 3 \\ -5 & 3 & 1 \end{bmatrix}$$

$$\Rightarrow A = \begin{bmatrix} 1 & 0 & 2 \\ 2 & -1 & 3 \\ -1 & 1 & 1 \end{bmatrix}$$

$$\text{Tr}(A) - \text{Tr}(B) = 1 - (-1) = 2$$

SECTION B

1. Let z_1, z_2 be the roots of the equation $z^2 + az + 12 = 0$ and z_1, z_2 form an equilateral triangle with origin. Then, the value of $|a|$ is _____.

Ans: 6

Sol:

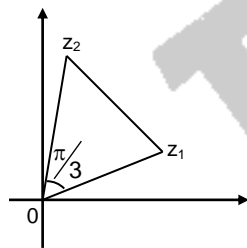

$$z_2 = z_1 \left(\cos \frac{\pi}{3} + i \sin \frac{\pi}{3} \right) = z_1 \left(\frac{1}{2} + \frac{\sqrt{3}}{2} i \right)$$

$$z_1 + z_2 = \frac{-a}{1} = -a$$

$$\Rightarrow z_1 \left(\frac{3}{2} + \frac{\sqrt{3}}{2} i \right) = -a$$

$$|a| = |z_1| \sqrt{\frac{9}{4} + \frac{3}{4}} = \frac{\sqrt{12}}{2} |z_1| = \sqrt{3} |z_1|$$

$$z_1 z_2 = \frac{12}{1} \Rightarrow z_1 z_1 \left(\frac{1}{2} + \frac{\sqrt{3}}{2} i \right) = 12$$

$$\Rightarrow |z_1|^2 \left| \frac{1}{2} + \frac{\sqrt{3}}{2} i \right| = 12$$

$$\Rightarrow |z_1|^2 \times 1 = 12 \Rightarrow \frac{|a|^2}{3} = 12$$

$$\Rightarrow |a|^2 = 36 \Rightarrow |a| = 6$$

2. The mean age of 25 teachers in a school is 40 years. A teacher retires at the age of 60 years and a new teacher is appointed in his place. If the mean age of the teachers in this school now is 39 years, then the age (in years) of the newly appointed teacher is _____.

Ans: 35

Sol: Sum of the ages = 25×40
 New sum after retirement = $(25 \times 40) - 60 + x$
 New mean = $\frac{1000 - 60 + x}{25} = 39$
 $\Rightarrow x = 35$

3. Let $f(x)$ and $g(x)$ be two functions satisfying $f(x^2) + g(4-x) = 4x^3$ and $g(4-x) + g(x) = 0$, then

the value of $\int_{-4}^4 f(x^2) dx$ is _____.

Ans: 512

Sol: $\int_{-4}^4 f(x^2) dx = 2 \int_0^4 f(x^2) dx$
 [$\because f(x^2)$ is even function]
 Given that $f(x^2) + g(4-x) = 4x^3$ ---- (1)
 $g(4-x) + g(x) = 0$ ---- (2)
 $f(x^2) - g(x) = 4x^3 \Rightarrow f(x^2) = 4x^3 + g(x)$
 $\therefore \int_{-4}^4 f(x^2) dx = 2 \int_0^4 [4x^3 + g(x)] dx$
 Given that $g(4-x) + g(x) = 0$
 $x = 2 \Rightarrow g(2) + g(2) = 0 \Rightarrow g(2) = 0$
 $x = 3 \Rightarrow g(1) + g(3) = 0 \Rightarrow g(3) = -g(1)$
 $x = 4 \Rightarrow g(0) + g(4) = 0 \Rightarrow g(4) = -g(0)$ etc

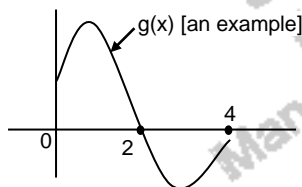

Clearly $\int_0^4 g(x) = 0$

$$\int_{-4}^4 f(x^2) dx = 8 \left[\frac{x^4}{4} \right]_0^4 + 0 = 2 \times 4^4 = 512$$

4. The equation of the planes parallel to the plane $x - 2y + 2z - 3 = 0$ which are at unit distance from the point $(1, 2, 3)$ is $ax + by + cz + d = 0$. If $(b - d) = K(c - a)$, then the positive value of K is _____.

Ans: 4

Sol: The required plane is $x - 2y + 2z + k = 0$

Distance from (1, 2, 3) is $\frac{|1 - 4 + 6 + k|}{\sqrt{1 + 4 + 4}}$

$$= \frac{|k + 3|}{3} = 1 \Rightarrow |k + 3| = 3 \Rightarrow k + 3 = \pm 3$$

$$\Rightarrow k = 0 \text{ or } k = -6$$

If $k = 0$, plane : $x - 2y + 2z = 0$

$\Rightarrow a = 1, b = -2, c = 2, d = 0$

$$k = \frac{-1}{2} (< 0)$$

If $k = -6$, plane : $x - 2y + 2z - 6 = 0$

$a = 1, b = -2, c = 2, d = -6$

$$k = \frac{b - d}{c - a} = \frac{-2 + 6}{2 - 1} = 4$$

5. The missing value in the following figure is _____.

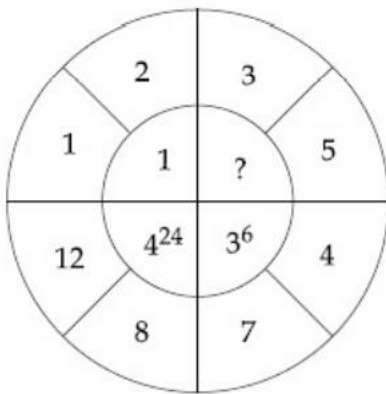

Ans: 4

Sol: $2^{[2 \times (3 - 2)]} = 2^2 = 4$

6. If $f(x) = \int \frac{5x^8 + 7x^6}{(x^2 + 1 + 2x^7)^2} dx$, ($x \geq 0$), $f(0) = 0$ and $f(1) = \frac{1}{K}$, then the value of K is

_____.

Ans: 4

Sol: $f(x) = \int \frac{5x^8 + 7x^6}{(x^2 + 1 + 2x^7)^2} dx = \int \frac{x^{-14}(5x^8 + 7x^6)}{x^{-14}(x^2 + 1 + 2x^7)^2} dx$
 $= \int \frac{5x^{-6} + 7x^{-8}}{(x^{-7})^2(x^2 + 1 + 2x^7)^2} dx = \int \frac{5x^{-6} + 7x^{-8}}{(2 + x^{-7} + x^{-5})^2} dx$
 $2 + x^{-7} + x^{-5} = t$
 $\Rightarrow (-7x^{-8} - 5x^{-6}) dx = dt$
 $\Rightarrow (7x^{-8} + 5x^{-6}) dx = -dt$
 $\Rightarrow \int \frac{-dt}{t^2} = \frac{1}{t} + C = \frac{1}{2 + x^{-7} + x^{-5}} + C = \frac{x^7}{2x^7 + 1 + x^2} + C$
 $f(0) = 0 \Rightarrow C = 0$
 $f(1) = \frac{1}{2 + 1 + 1} = \frac{1}{4} \Rightarrow k = 4$

7. Let the plane $ax + by + cz + d = 0$ bisect the line joining the points $(4, -3, 1)$ and $(2, 3, -5)$ at the right angles. If a, b, c, d are integers, then the minimum value of $(a^2 + b^2 + c^2 + d^2)$ is _____.

Ans: 28

Sol: Mid point : $(3, 0, -2)$
 DR of the normal : $2, -6, 6$ or $1, -3, 3$
 Plane : $1(x - 3) - 3(y - 0) + 3(z + 2) = 0$
 $\Rightarrow x - 3 - 3y + 3z + 3 = 0 \Rightarrow a^2 + b^2 + c^2 + d^2 = 1 + 9 + 9 + 9 = 28$

8. The number of solutions of the equation $|\cot x| = \cot x + \frac{1}{\sin x}$ in the interval $[0, 2\pi]$ is _____.

Ans: 1

Sol: $|\cot x| = \cot x + \frac{1}{\sin x}$ ---- (1)

Let $\cot x = t$

$$\Rightarrow \operatorname{cosec}^2 x = 1 + t^2 \Rightarrow \operatorname{cosec} x = \pm\sqrt{1+t^2}$$

$$\therefore |t| = t \pm \sqrt{1+t^2}$$

Case 1

$$|t| = t + \sqrt{1+t^2}$$

$$\text{If } t > 0, t = t + \sqrt{1+t^2} \Rightarrow \sqrt{1+t^2} = 0 \text{ (false)}$$

$$\text{If } t < 0, -t = t + \sqrt{1+t^2} \Rightarrow -2t = \sqrt{1+t^2}$$

$$\Rightarrow 4t^2 = 1 + t^2 \Rightarrow 3t^2 = 1 \Rightarrow t^2 = \frac{1}{3} \Rightarrow t = \frac{-1}{\sqrt{3}} \quad (\because t < 0)$$

$$\Rightarrow \cot x = \frac{-1}{\sqrt{3}} \Rightarrow \tan x = -\sqrt{3}$$

$$x = \pi - \frac{\pi}{3}$$

(If $x = 2\pi - \frac{\pi}{3}$, RHS of (1) will be negative hence not possible)

Case 2

$$|t| = t - \sqrt{1+t^2}$$

$$\text{If } t > 0, t = t - \sqrt{1+t^2} \Rightarrow \sqrt{1+t^2} = 0 \text{ (false)}$$

$$\text{If } t < 0, -t = t - \sqrt{1+t^2} \Rightarrow \sqrt{1+t^2} = 2t$$

\therefore (Not possible since LHS > 0 and RHS < 0)

9. The number of times the digit 3 will be written when listing the integers from 1 to 1000 is _____.

Ans: 300

Sol: 3 can appear in the 1st, 2nd or 3rd position
 \therefore Required answer = $3 \times 10 \times 10 = 300$

10. A square ABCD has all its vertices on the curve $x^2 + y^2 = 1$. The midpoints of its sides also lie on the same curve. Then, the square of area of ABCD is _____.

Ans: 80

Sol:

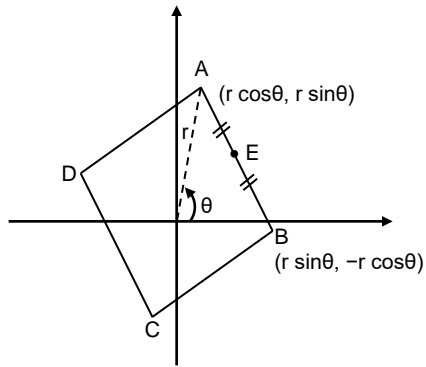

$$E\left(\frac{r(\cos\theta + \sin\theta)}{2}, \frac{r(-\cos\theta + \sin\theta)}{2}\right)$$

$$(r \cos\theta)^2 + (r \sin\theta)^2 = 1 \Rightarrow r^4 \sin^2\theta = 1$$

$$\Rightarrow r^2 \sin\theta \cos\theta = 1$$

$$\Rightarrow \sin\theta \cos\theta = \frac{1}{r^2} \Rightarrow \sin 2\theta = \frac{2}{r^2}$$

$$\Rightarrow \sin^2 2\theta = \frac{4}{r^4}$$

$$\left[\frac{r(\cos\theta + \sin\theta)}{2}\right]^2 \cdot \left[\frac{r(\cos\theta + \sin\theta)}{2}\right]^2 = 1$$

$$\frac{r^4}{16} (\cos^2\theta - \sin^2\theta)^2 = 1 \Rightarrow \cos^2 2\theta = \frac{16}{r^4}$$

$$\sin^2 2\theta + \cos^2 2\theta = 1 \Rightarrow \frac{20}{r^4} = 1 \Rightarrow r^4 = 20$$

$$\text{Area} \frac{1}{2} (\text{diagonal})^2 = \frac{1}{2} \times (2r)^2 = 2r^2 = 2\sqrt{20}$$

$$(\text{Area})^2 = 4 \times 20 = 80$$